

NOTE:ALL MATERIAL COMPLIANT ROHS STANDARD

REVISION INFORMATION

| Rev. | Rev. Date | Modified By | Brief Description |
|------|-----------|-------------|-------------------|
| | | | |

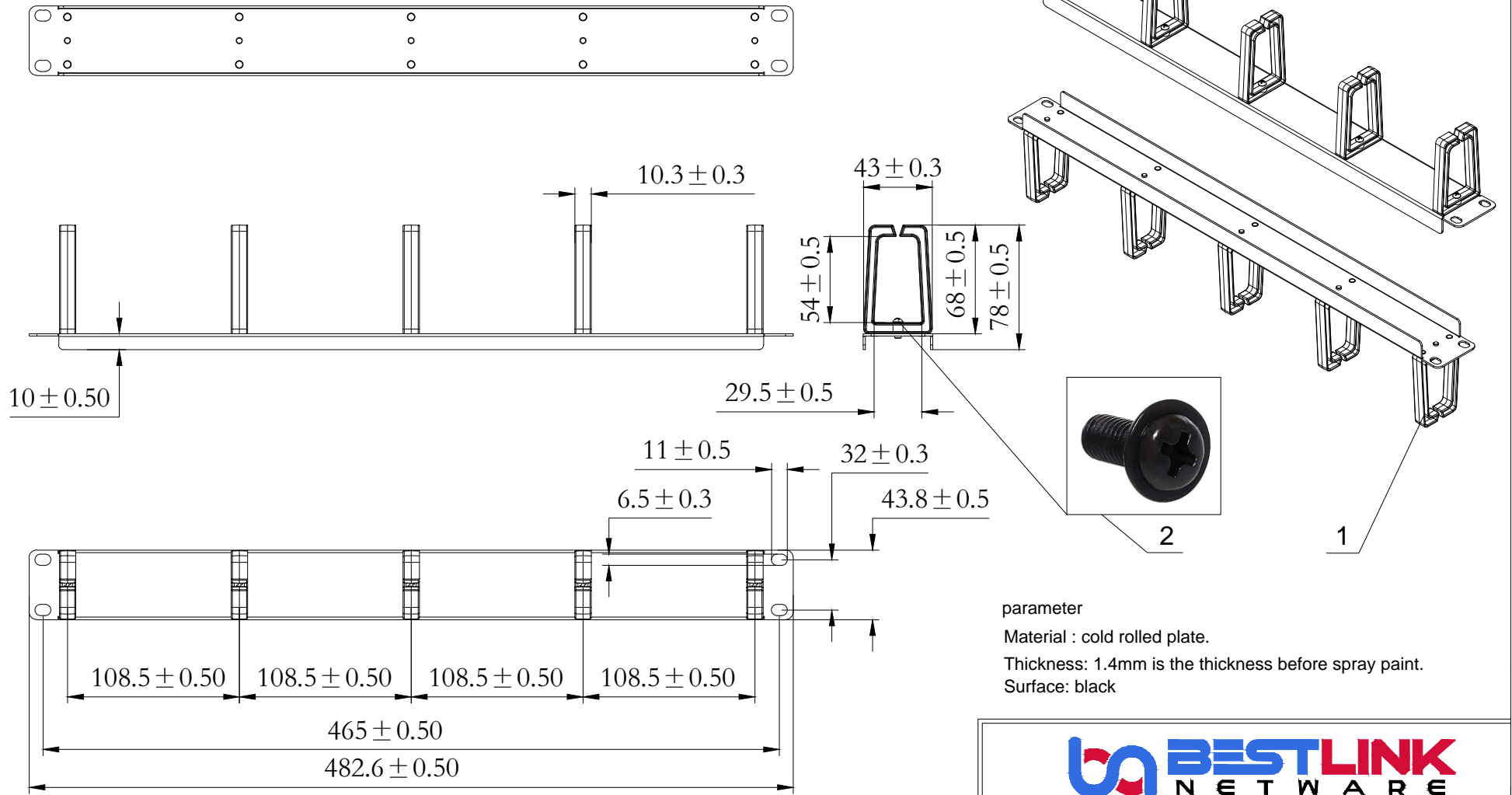

parameter

Material : cold rolled plate.

Thickness: 1.4mm is the thickness before spray paint.

Surface: black



| NO. | PART NAME | SPECIFICATION DESCRIPTION | QTY | UNIT |
|-----|----------------------|---------------------------|-----|------|
| ③ | | | | |
| ② | Cross pan head screw | M4 xL10 mm (black) | 5 | PCS |
| ① | Plastic wire ring | 68*43*10.2mm | 5 | PCS |

| | | |
|-------------|---------------------|-----------------------------------------------|
| DRAWN BY | DATE: 2020/08/14 | DESCRIPTION: 1U Cable Management 1.75**19" |
| CHECKED BY | SHEET 1of1 | ITEM NO. 102264 |
| APPROVED BY | SCALE 1:1 | REV. 00 UNIT:mm |

NOTE: CARTON MATERIAL MUST BE A=A

| REVISION INFORMATION | | | |
|----------------------|-----------|-------------|-------------------|
| Rev. | Rev. Date | Modified By | Brief Description |
| | | | |

Inside the box

Description: 1U Cable Management
1.75"x19", Plastic Ring
QTY : 1 PCS

typeface:Arial
Sticker size : 100*35mm

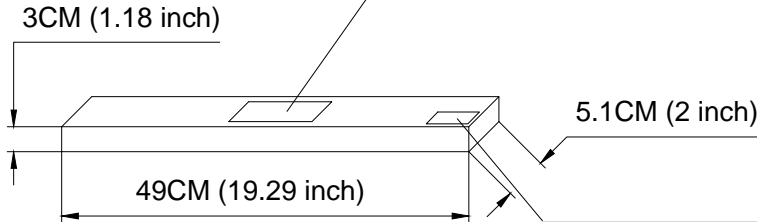

Unit package
Size: 49*5.1*3 CM(19.29*2*1.18inch)
Weight : 0.838 LBS(0.38KG)
QTY : 1PCS

AT the bottom of the box

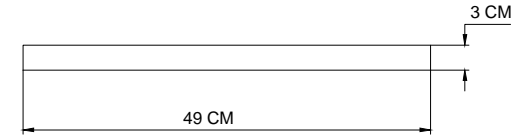

WARNING: This product contains PVC
Which can expose you to chemicals including
diisononyl phthalate (DINP) which is known
to the State of California to cause cancer.
For more information, go to
www.P65Warnings.ca.gov

typeface:Arial
Sticker size : 50*20mm

outside the box

Main Mark

P/O :
P/N : 102264
QTY : 30 PCS
C/NO :
MADE IN CHINA

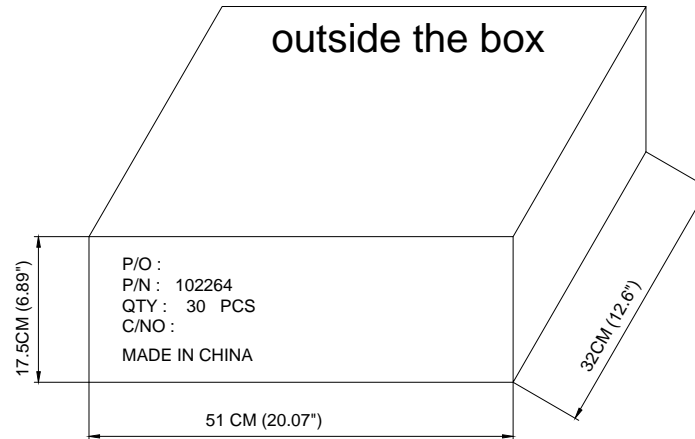

Carton Size : 51CM(20.07") X 32 CM(12.6") X 17.5 CM(6.89")
Carton Quantity : 30 Pcs
Carton Weight : 26.5 LBS(12Kg)

Side Mark

P/N: 102264
QTY: 30 PCS
N.W: 11.3 KGS
G.W: 12 KGS
Date code:
Vender Code:



| NO. | PART NAME | SPECIFICATION DESCRIPTION | QTY | UNIT |
|-----|-----------|---------------------------|-----|------|
| ③ | | | | |
| ② | | | | |
| ① | | | | |

| | | |
|-------------|---------------------|-------------------------------------------------------------------------------------------------------|
| DRAWN BY | DATE: 2020/09/12 | DESCRIPTION: 1U Cable Management 1.75**19" |
| CHECKED BY | SHEET 1of1 | ITEM NO. 102264 |
| APPROVED BY | SCALE 1:1 | REV. 00 UNIT:mm  |

NOTE:ALL MATERIAL COMPLIANT ROHS STANDARD

REVISION INFORMATION

| Rev. | Rev. Date | Modified By | Brief Description |
|------|-----------|-------------|-------------------|
| | | | |

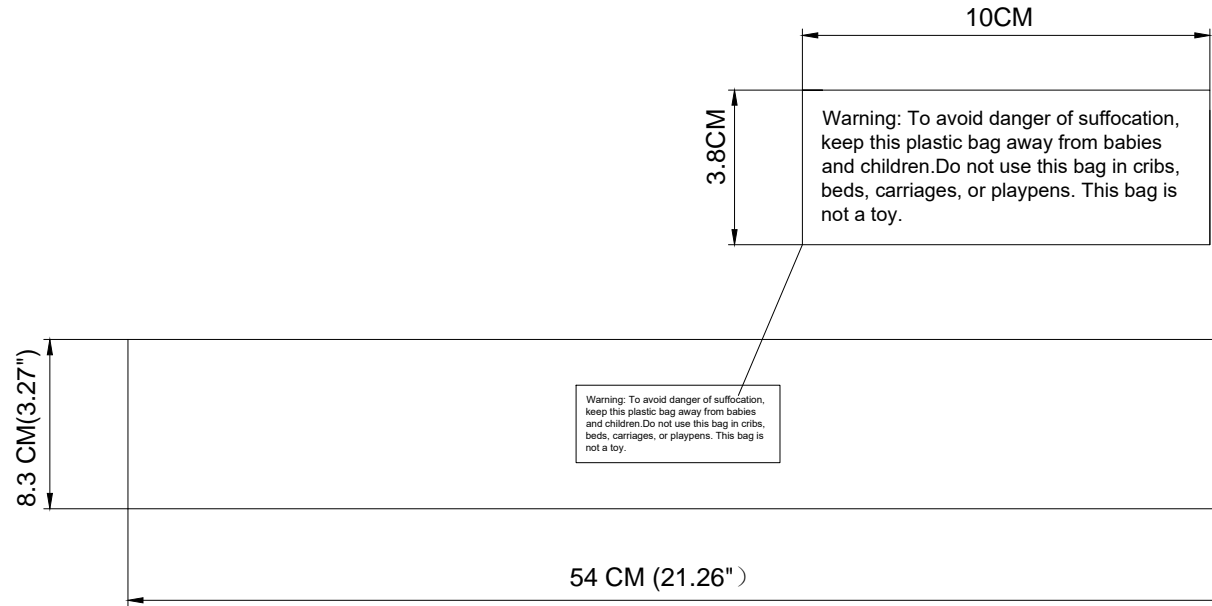

| NO. | PART NAME | SPECIFICATION DESCRIPTION | QTY | UNIT |
|-----|-----------|---------------------------|-----|------|
| ① | | | | |
| ② | | | | |
| ③ | | | | |

| | | | | |
|-------------|---------------------|--------------------------------------------------|---------|--|
| DRAWN BY | DATE: 2020/08/14 | DESCRIPTION: PE bag and warning(21.26**3.27") | | |
| CHECKED BY | SHEET 1of1 | ITEM NO. | | |
| APPROVED BY | SCALE 1:1 | REV. 00 | UNIT:mm | |