

NOTE: CARTON MATERIAL MUST BE A=A

REVISION INFORMATION

Rev.	Rev. Date	Modified By	Brief Description

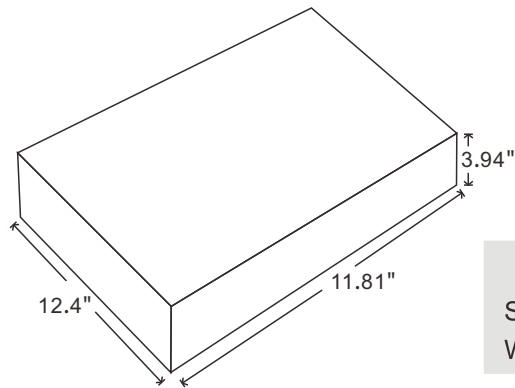

Unit package  
 Size: 11.81"(L) \* 12.4"(W) \* 3.94"(H)  
 Weight: 3.96LBS

P/O:  
 P/N: 502848  
 Q'TY:  
 C/NO.:  
  
 MADE IN CHINA

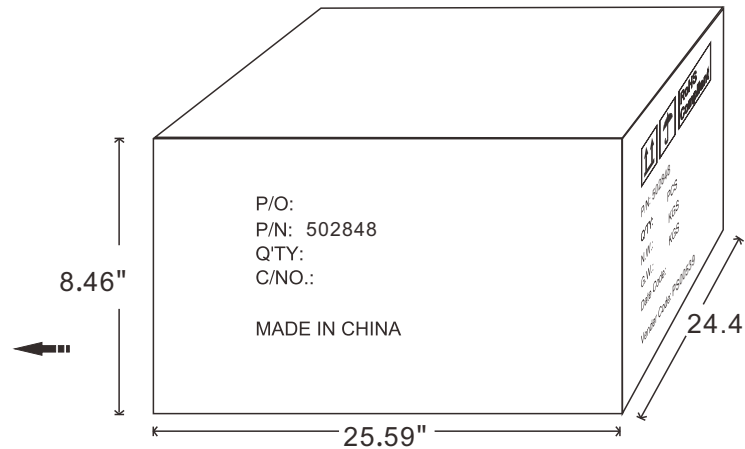

Carton Size: 25.59"(L) \* 24.4"(W) \* 8.46"(H)  
 Carton Quantity: 8pcs  
 Carton Weight: 34.1LBS

		<b>RoHS Compliant</b>
P/N: 502848		
Q'TY:	PCS	
N.W.:	KGS	
G.W.:	KGS	
Date Code:		
Vender Code:	PS00539	

DRAWN BY	DATE: 2015/6/4	DESCRIPTION: Aluminum Wall Mounts 17"-37" Tilt/Swivel	
CHECKED BY	SHEET 1 of 2	ITEM NO. 502848	
APPROVED BY	SCALE 1: 1	REV. 00	UNIT: mm