

NOTE: CARTON MATERIAL MUST BE A=A

REVISION INFORMATION

Rev.	Rev. Date	Modified By	Brief Description

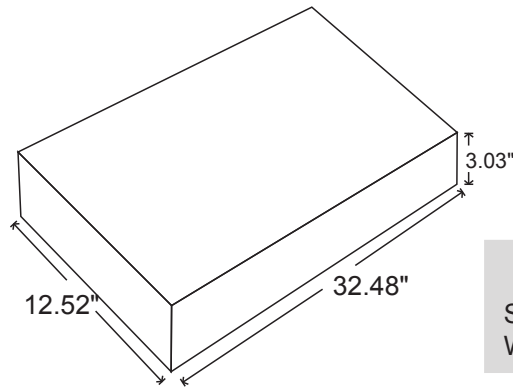

Unit package
 Size: 32.48"(L)*12.52"(W)*3.03"(H)
 Weight: 13.97LBS

P/O:
 P/N: 502695BK
 Q'TY:
 C/NO.:

 MADE IN CHINA

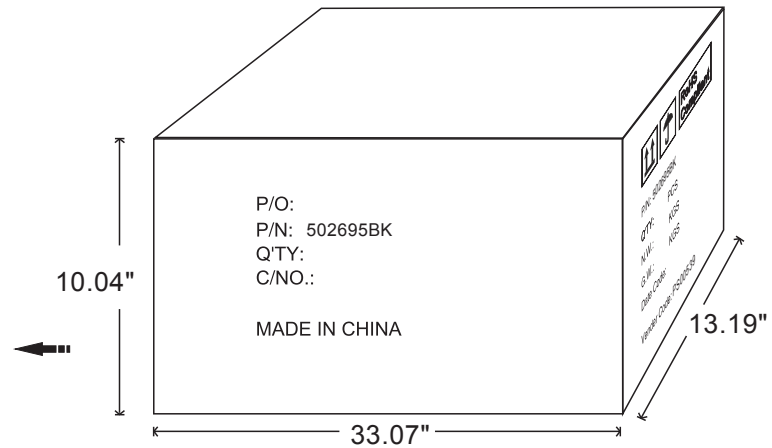

Carton Size: 33.07"(L)*13.19"(W)*10.04"(H)
 Carton Quantity: 3pcs
 Carton Weight: 44.22LBS

		RoHS Compliant
P/N: 502695BK		
Q'TY: PCS		
N.W.: KGS		
G.W.: KGS		
Date Code:		
Vender Code: PS00539		

DRAWN BY	DATE: 2021/2/18	DESCRIPTION: Universal TV Ceiling Mount PLB-CE1046-02	
CHECKED BY	SHEET 1 of 2	ITEM NO. 502695BK	
APPROVED BY	SCALE 1:1	REV. 00	UNIT:mm

