

NOTE: ALL MATERIAL COMPLIANT ROHS STANDARD

REVISION INFORMATION			
Rev.	Rev. Date	Modified By	Brief Description
A/0	2016/5/03	Susam	NEW

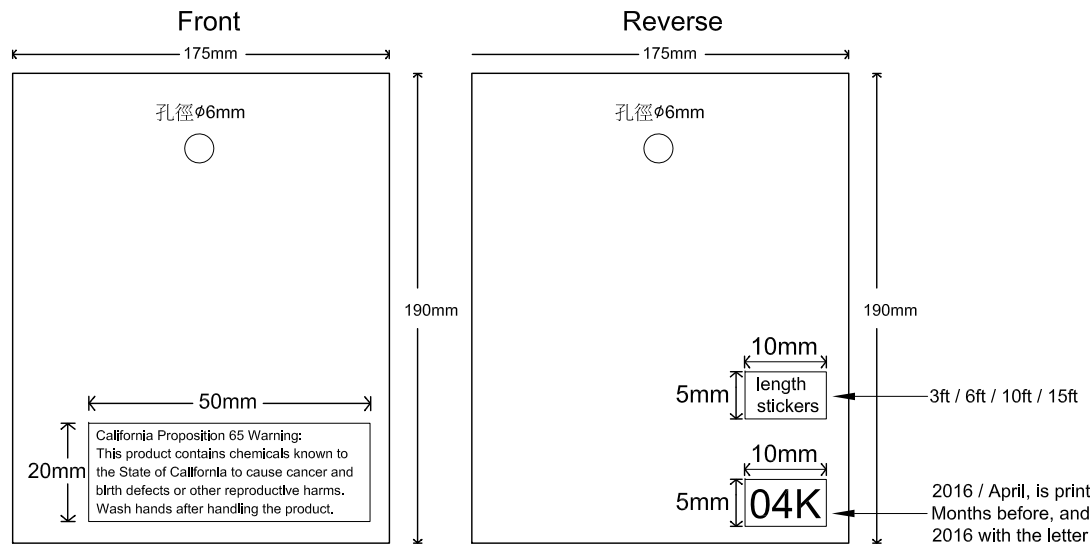

PE bag size	part NO.	length/ft	QTY	carton size
150x320x0.08mm	210245CB	3ft	130	50x32x23cm
150x320x0.08mm	210246CB	6ft	80	50x32x23cm
150x320x0.08mm	210247CB	10ft	50	50x32x23cm
150x320x0.08mm	210248CB	15ft	40	50x32x23cm

Main Mark

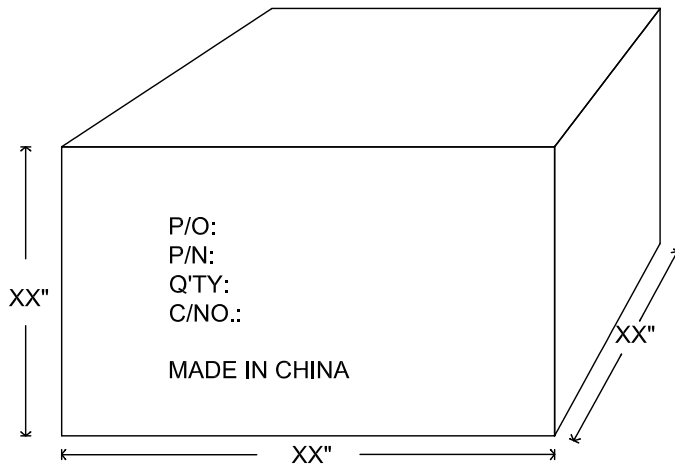
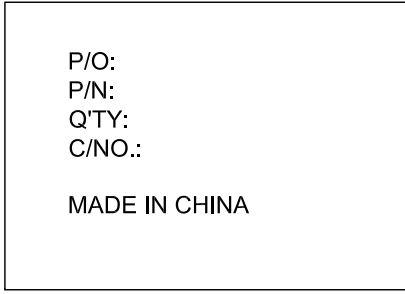

Side Mark

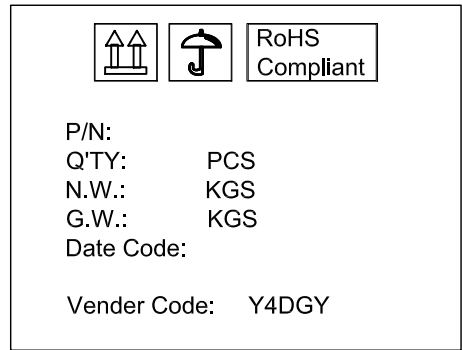

DRAWN BY Susam	DATE: 2016/5/03	DESCRIPTION:	
CHECKED BY QinRao	SHEET 1 of 1	ITEM NO.	
APPROVED BY	SCALE 1:1	REV. 00	UNIT: mm

