

NOTE: CARTON MATERIAL MUST BE A=A

REVISION INFORMATION

| PART NO. | PE BAG SIZE INCHE | Lenth ft | CARTON SIZE INCHE | QTY | GW LBS |
|----------|-------------------|----------|-------------------|-----|--------|
| 210136BK | 5.91* 7.09        | 1        | 20.08*12.20* 9.06 | 100 | 37.48  |
| 210137BK | 5.91* 7.09        | 3        | 20.08*12.20* 9.45 | 100 | 41.37  |
| 210138BK | 5.91* 7.09        | 6        | 20.08*12.20* 9.45 | 50  | 37.48  |
| 210139BK | 5.91* 7.09        | 10       | 20.08*12.20* 9.06 | 30  | 37.48  |
| 210140BK | 5.91* 7.09        | 15       | 20.08*12.20* 9.45 | 30  | 37.48  |
| 210141BK | 5.91* 7.09        | 25       | 20.08*12.20* 9.06 | 10  | 37.48  |

| Rev. | Rev. Date | Modified By | Brief Description |
|------|-----------|-------------|-------------------|
|      |           |             |                   |

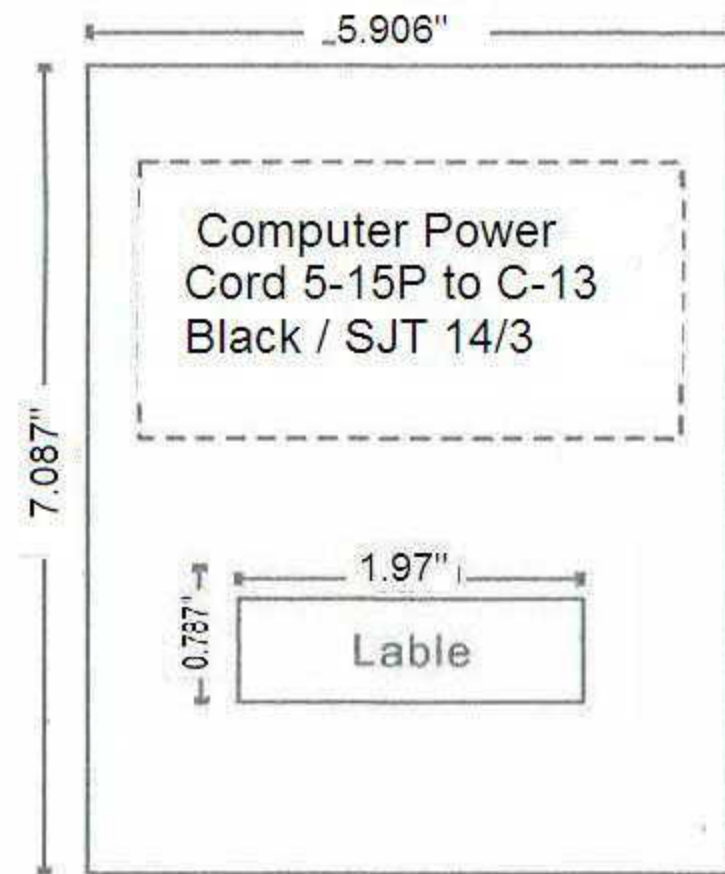

Side Mark

RoHS  
Compliant

P/N:

QTY: PCS

N.W.: KGS

G.W.: KGS

Date Code: 04-2016

Vender Code: PS01051

Main Mark

P/O:  
P/N:  
QTY:  
C/NO.:

MADE IN CHINA

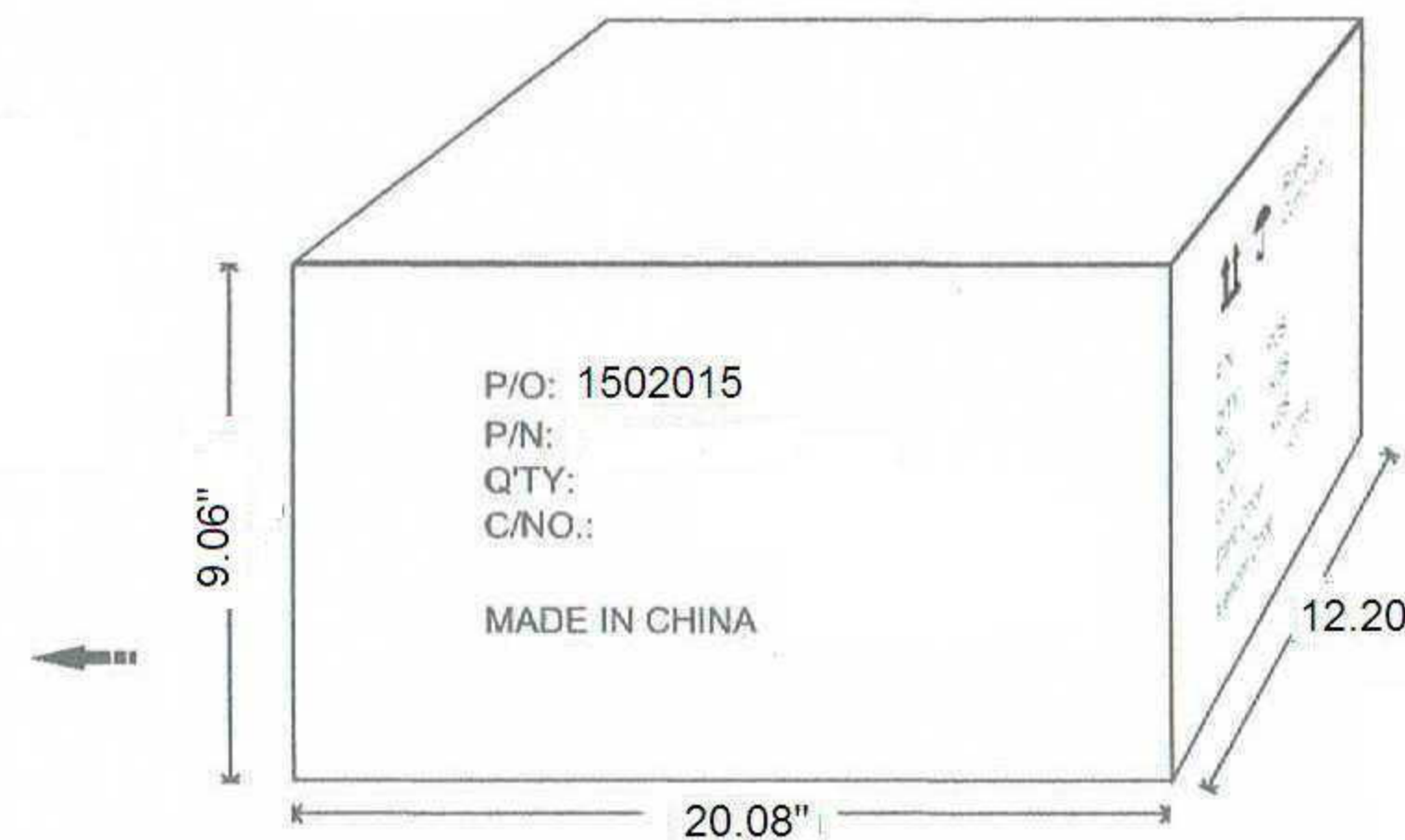

|                   |                  |                   |
|-------------------|------------------|-------------------|
| DRAWN BY Wang     | DATE: 2015/12/15 | DESCRIPTION:      |
| CHECKED BY Zhang  | SHEET 1 of 2     | ITEM NO. 210136BK |
| APPROVED BY Zhang | SCALE 1:1        | REV. 00 UNIT:mm   |