

NOTE:ALL MATERIAL COMPLIANT ROHS STANDARD

REVISION INFORMATION

Rev.	Rev. Date	Modified By	Brief Description

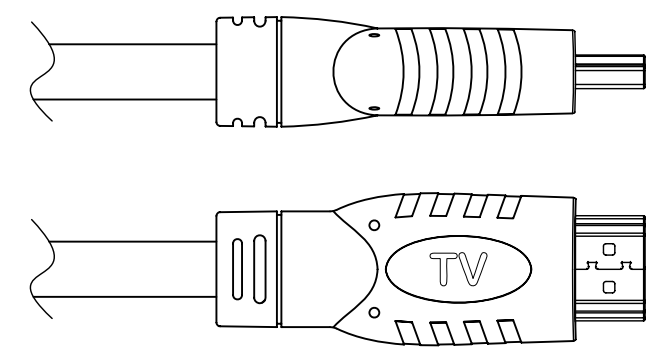
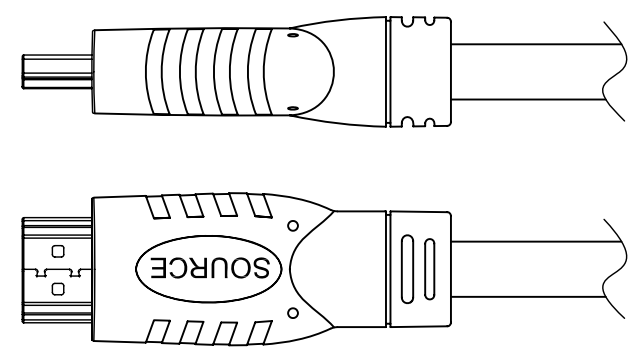
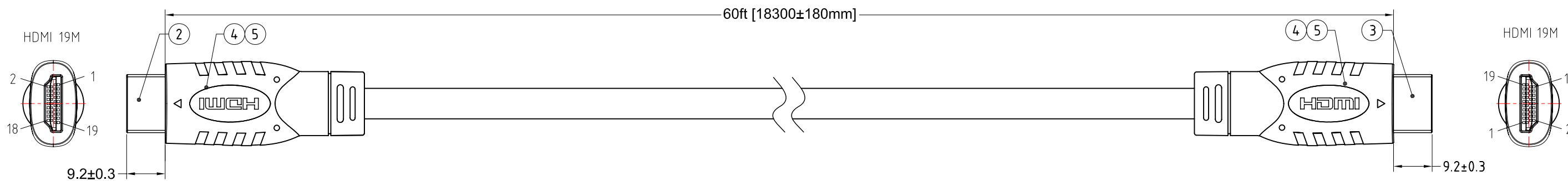

Electrical character:
1)100% 1080P、4K@60Hz、3D testing

PIN ASSIGNMENT(1.4v)

HDMI 19M	Color	PCBA,S7/HT8181	HDMI 19M
3	Red	PCBA,S7/HT8181	3 TMDS data2-
1	White		1 TMDS data2+
2	Drain		2 TMDS data2 Shield
6	Green		6 TMDS data1-
4	White		4 TMDS data1+
5	Drain		5 TMDS data1 Shield
9	Blue		9 TMDS data0-
7	White		7 TMDS data0+
8	Drain		8 TMDS data0 Shield
12	Brown		12 TMDS Clock-
10	White		10 TMDS Clock+
11	Drain		11 TMDS Clock Shield
19	Black		19 HPD/ HEAC-
14	White		14 Utility/ HEAC+
17	Drain		17 DDC/CEC/HEAC GND
13	White		13 CEC
15	Yellow		15 SCL
16	Orange		16 SDA
18	Red	18 +5V Power	
SHELL	Braid+Drain	SHELL	

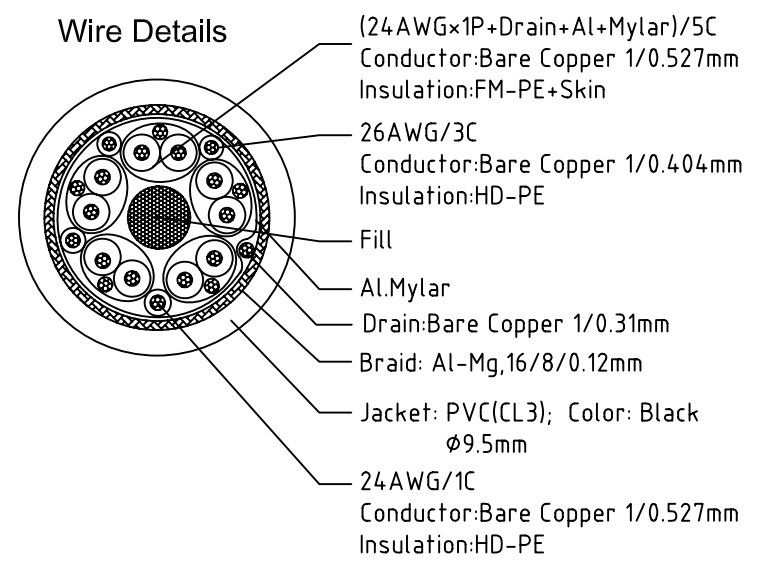

NO.	PART NAME	SPECIFICATION DESCRIPTION	QTY	UNIT
①	Cable	UL20276 (24#BC/1P+ADM)/5C+26#/3C+24#/1C+F+A+D+B(16/8/0.12,Al-Mg)+PVC,Black,OD9.5mm		
②	HDMI_Conn	HDMI A/M,PIN G/F,Black Insulation,Steel-Shell(G/F Plated),Solder type		
③	HDMI Conn+PCBA	HDMI A/M(G/F Plated)+PCBA(S7/HT8181)		
④	Innermold	PE,Low density		
⑤	Overmold	PVC,45Pa,Black		

Unless specified on the drawing, tolerances are per the follows:

.	+1
.x	+0.2
.xx	+0.05

DRAWN BY	DATE: 2019/08/19	DESCRIPTION: HDMI A/M TO HDMI A/M Cable
CHECKED BY	SHEET 1of2	ITEM NO. 181419
APPROVED BY	SCALE None	REV. 0.0 UNIT:mm

NOTE: CARTON MATERIAL MUST BE A=A

REVISION INFORMATION			
Rev.	Rev. Date	Modified By	Brief Description

FRONT

BACK

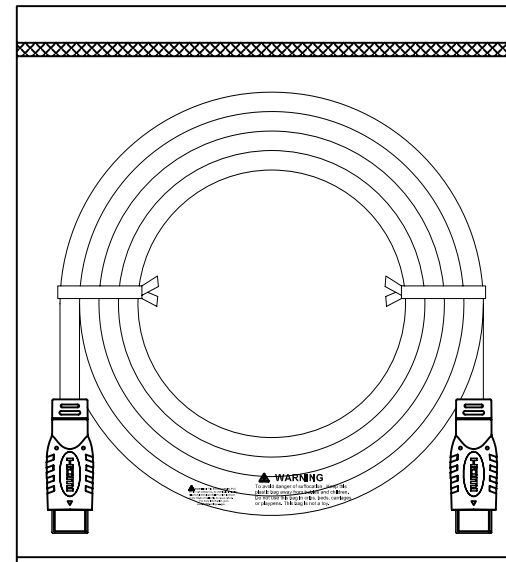
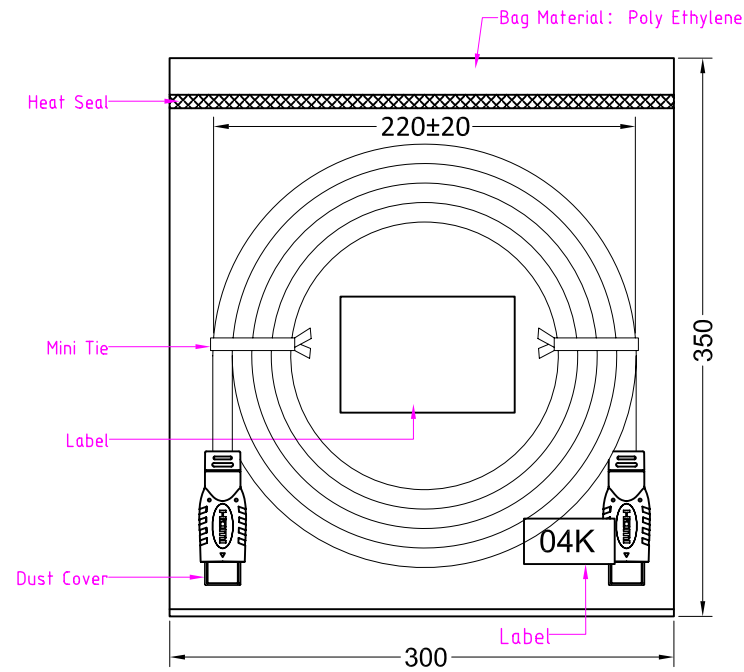

12pcs →

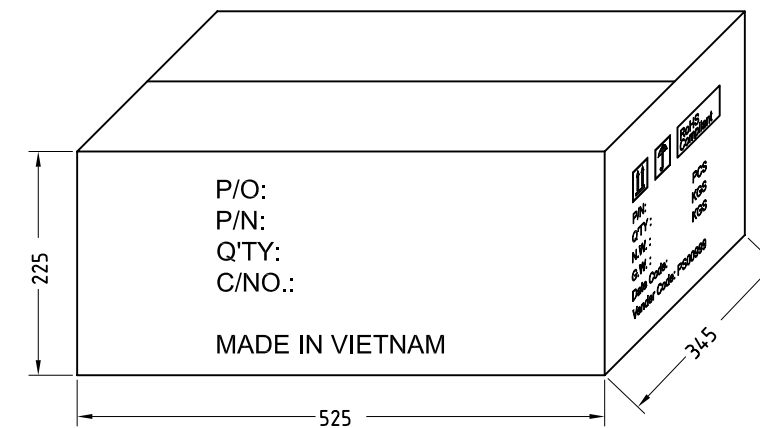

MAIN MARK

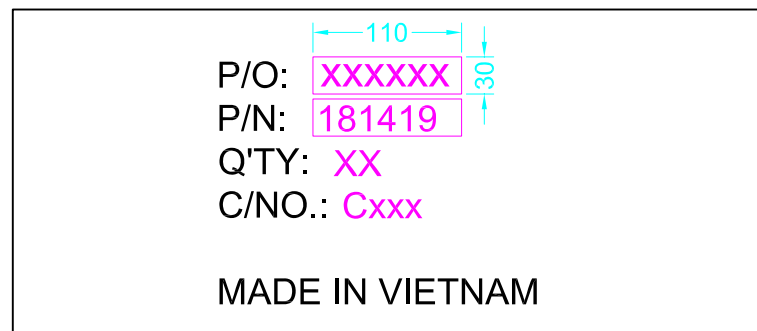

Label:
Size: 60 x 40 mm

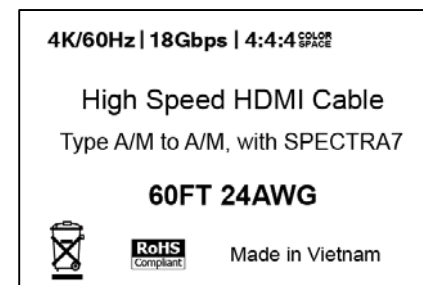

Label:
Size: 10 x 5 mm

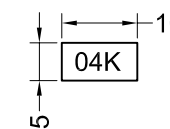

Packing Instruction:

1. First of all, protect the connector with dust covers, coil the cable (see attached). Secure the cable with cable tie, and then pack each cable with an individual PE bag. The label is attached to the PE bag.
2. Seal the PE bag with heat sealing machine.
3. Use a waterproof bag to pack the products before going into master carton. Make sure each individual cable is staggered and positioned tidily. A paperboard is needed in both the bottom and the top of the products.
4. See shipping mark on the left.

SIDE MARK

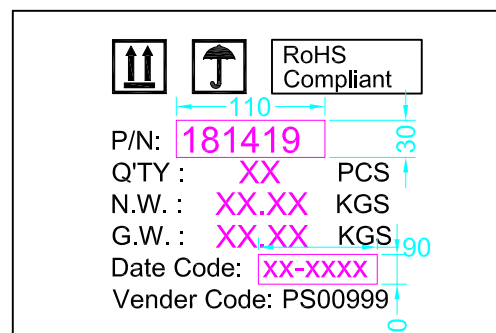

Carton Size: 20.67"(L)*13.58"(W)*8.86"(H)
Carton Quantity: 8 pcs
Carton Weight: 25.78 LBS

DRAWN BY	DATE: 2019/08/19	DESCRIPTION: HDMI A/M TO HDMI A/M Cable
CHECKED BY	SHEET 2of2	ITEM NO. 181419
APPROVED BY	SCALE None	REV. 0.0 UNIT:mm