

NOTE: ALL MATERIAL COMPLIANT ROHS STANDARD

REVISION INFORMATION			
Rev.	Rev. Date	Modified By	Brief Description
A0	2016.2.18	LM	C5E UTP 24AWG PANEL TO RJ45
A1	2016.7.15	LM	ADD THE SIZE OF SCREW
A2	2016.8.01	LM	ADD THE SIZE OF MOLD

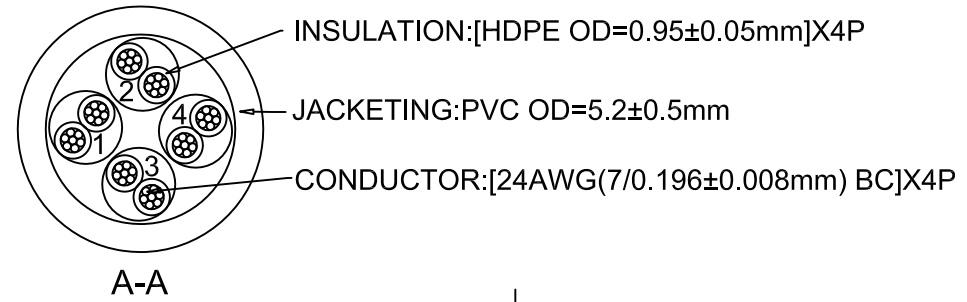
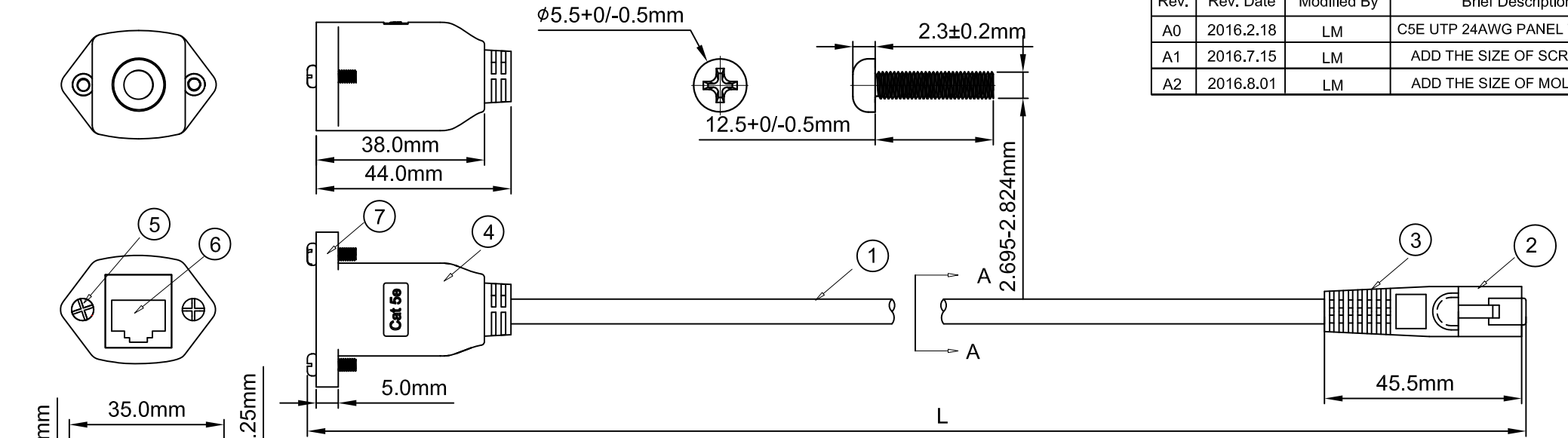

SUGGESTION:
THE PLUG IS BEST TO BE MOLDED.

PACKING&NOTE:
1.WITH CLEAR POLIBAG INDIVIDUALLY
2.BY 10 FOR 1FT,2FT,3FT LENGTHS
3.ASSEMBLY PASSES CAT5E PERMANENT LINK TEST.USING FLUKE OR SIMILAR TEST EQUIPMENT

orange 1	green 2
white/orange	white/green
blue 3	brown 4
white/blue	white/brown

Length(FT)	Tolerance(mm)
1	25
2	50
3	50
4	50
6	100
10	100
15	150
25	150

NO.	PART NAME	SPECIFICATION DESCRIPTION	QTY	UNIT
⑦	NUT	UNC #4-40 NUT,EMBEDDED,ELECTROPLATE	2	PCS
⑥	JACK	C5E JACK ,WHITE HOUSING	1	PCS
⑤	SCREW	SCREW ,PAN-HEAD,UNC #4-40,5/16"(8mm) THREAD,0.3925"(12mm) LENGTH,ELECTROPLATE	2	PCS
④	MOLD	PLASTIC OVERMOLD WITH STRAIN RELIEF,EMBEDDED UNC #4-40 NUTX2, BU608 (3015U) PVC,HARD:60-70P	1	PCS
③	MOLD	PVC YUS-07 BU608 (3015U)	1	PCS
②	PLUG	C5E RJ45 PLUG MALE TRANSPARENT	1	PCS
①	CABLE	C5E UTP 24AWG CM,PRINTING COLOR WHITE,CABLE COLOR BU608 (3015U) PVC	1	PCS



DRAWN BY LM	DATE: 2016/08/01	DESCRIPTION: C5E UTP 24AWG PANEL TO RJ45
CHECKED BY JZY	SHEET 1 of 1	ITEM NO. XXXXX
APPROVED BY LANDER	SCALE 1:1	REV. 00