

NOTE: CARTON MATERIAL MUST BE A=A

REVISION INFORMATION

Rev.	Rev. Date	Modified By	Brief Description

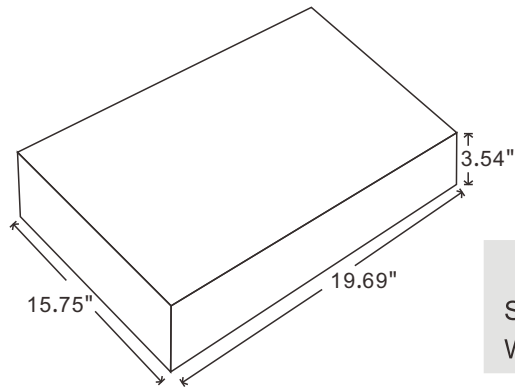

Unit package
 Size: 19.69"(L) * 15.75"(W) * 3.54"(H)
 Weight: 11.99LBS

P/O:
 P/N: 502872
 Q'TY:
 C/NO.:

 MADE IN CHINA

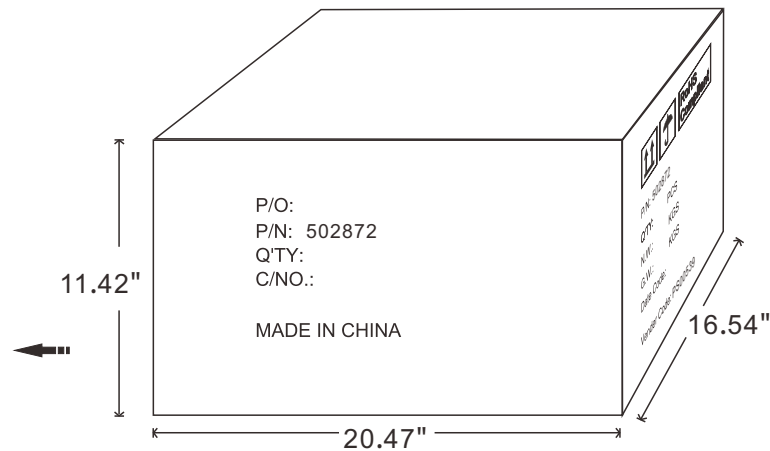

Carton Size: 20.47"(L) * 16.54"(W) * 11.42"(H)
 Carton Quantity: 3pcs
 Carton Weight: 37.84LBS

		RoHS Compliant
P/N: 502872		
Q'TY:	PCS	
N.W.:	KGS	
G.W.:	KGS	
Date Code:		
Vender Code: PS00539		

DRAWN BY	DATE: 2015/6/4	DESCRIPTION: Interactive Counterbalance Full-motion Wall Mount 26"~47"	
CHECKED BY	SHEET 1of2	ITEM NO. 502872	
APPROVED BY	SCALE 1: 1	REV. 00	UNIT:mm