

NOTE: ALL MATERIAL COMPLIANT ROHS STANDARD

REVISION INFORMATION

Rev.	Rev.Date	Modified By	Brief Description

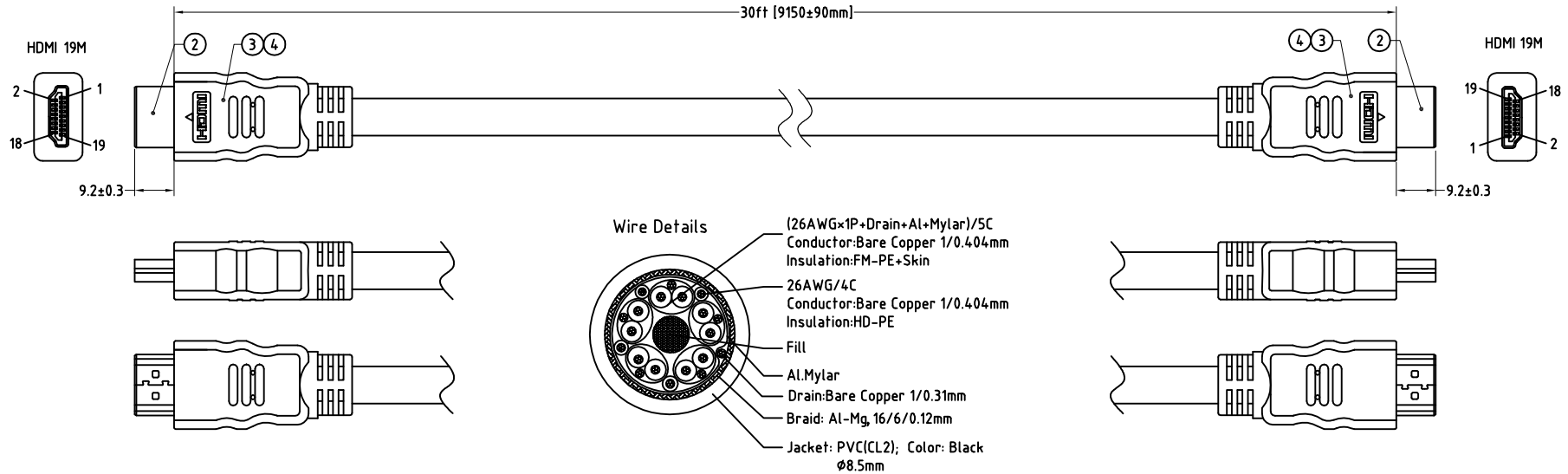

PIN ASSIGNMENT(1.4v)

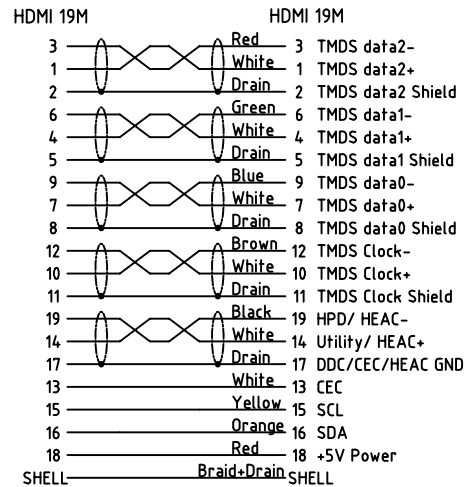

Electrical character:

- 100% Open/short/Intermittent testing
- Withstanding voltage: DC 300V AT 10ms.
- Insulation resistance: 10M Ohm(min)
- Residual operating current:
 - a. <1M=0.5mA; b. 1.0~2.0M=1.0mA;
 - c. 2.0~3.0M=2.0mA; d. 3.0~5.0M=3.0mA;
 - e. 5.0~10M=5.0mA; f. 10~15M=7.0mA;
- Conductive resistance: 5 Ohm Max

Label:
Size: 2.45" x 1.64"

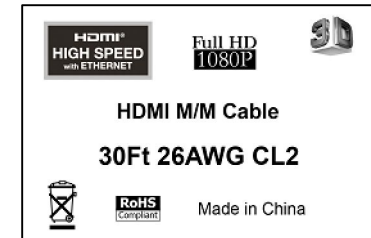
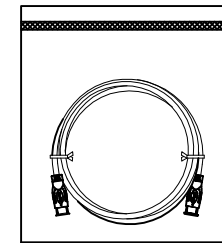

NO.	PART NAME	SPECIFICATION DESCRIPTION	QTY	UNIT
④	Overmold	PVC,45Pa,Black	N/A	G
③	Innermold	PE,Low density	N/A	G
②	HDMI_Conn	HDMI A/M,PIN G/F,Black Insulation,Steel-Shell(G/F Plated),Solder type	2	PCS
①	Cable	UL20276 (26#BC/1P+ADM)/5C+26#BC/4C+F+A+D+B(16/6/0.12,Al-Mg)+PVC(CL2),Black,Ø8.5mm	N/A	MM

DRAWN BY	DATE: 2014/07/04	DESCRIPTION: HDMI AM TO AM Cable,26#,30FT
CHECKED BY	SHEET 1 of 1	ITEM NO. 181290
APPROVED BY	SCALE None	REV. 00 UNIT: mm